

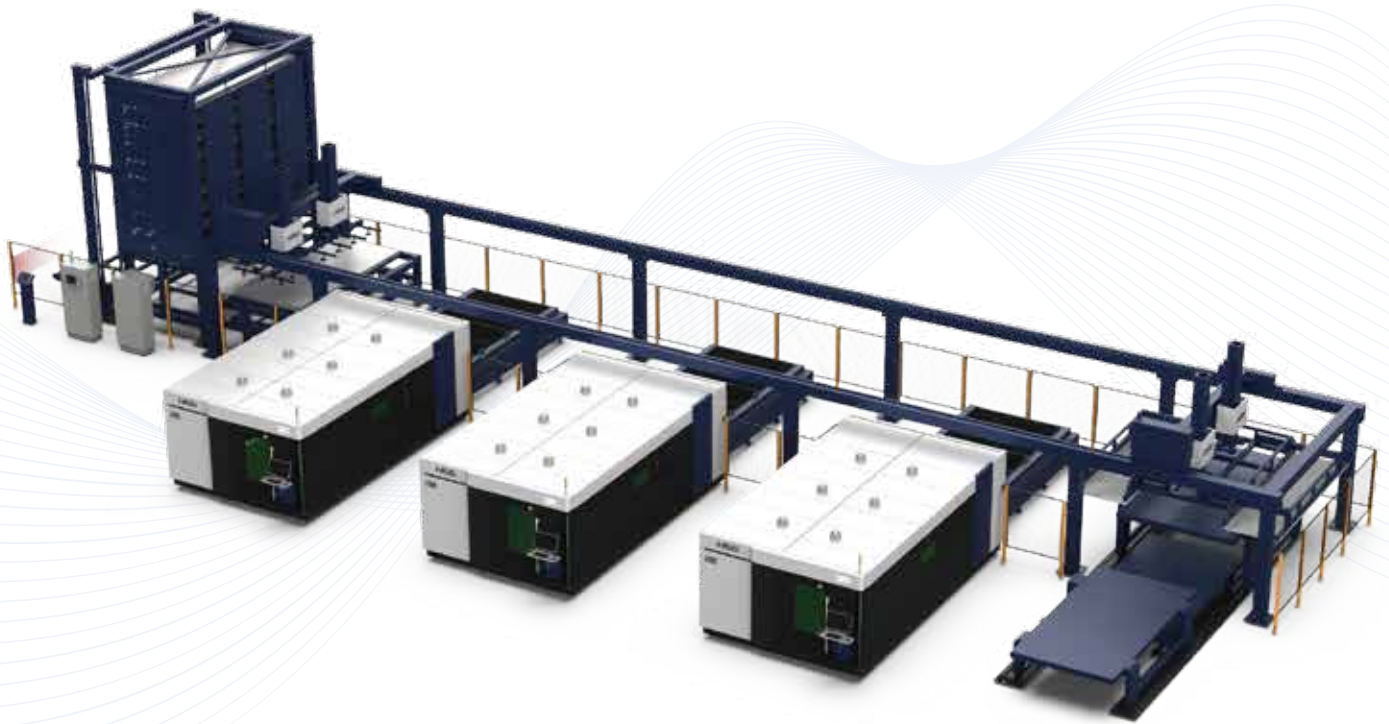

Cutting | Bending | Welding | Automation



Automation

✦ Intelligent Automation System ✦

Company Culture



MISSION

Intelligent manufacturing changes future



VALUES

Customer-focused and employee-based



VISION

Become a respectable enterprise in the global metal forming equipment field

Company Profile



13

Global Branches



100+

Countries Covered



4

Manufacturing Bases



30+

Global Service Outlets

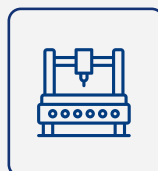

8,000+

Delivery Capability



96000m²

96,000m²

Occupied Area

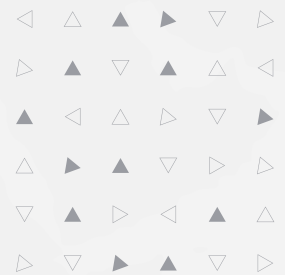

Store

Compact Structure | Small Floor Area | Unattended Management

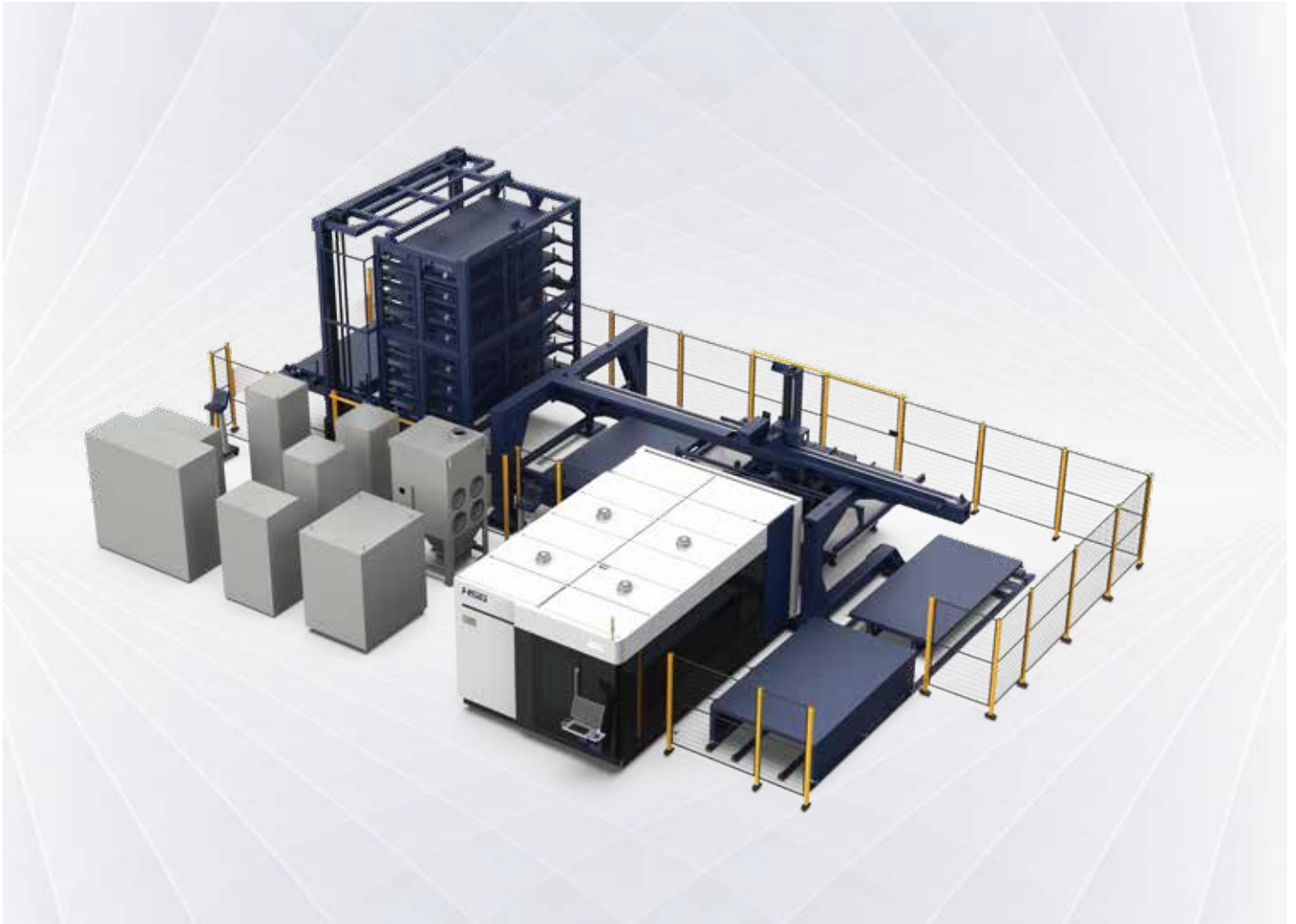

Technical Parameters

Model	Store3015-8-ALG200	Store3015-8-ALG400	Store3015-8-ALG800	Store4020-8-ALG400	Store4020-8-ALG800	Store4020-8-ALG1200
Matching Model Series				GX, GH		
Matching the size of the model	3015			4020		
Max Loading Weight	200kg	400kg	800kg	400kg	800kg	1200kg
Max Loading Sheet Size	3000mm*1500mm			4000mm*2000mm		

* Machine appearance, technical parameters, function description, data comparison shown in this page are from HSG in-house laboratory. All testing results and experimental data shall be subject to real machine.

ALG

Large Format, High Load | Module Design | Free Collocation

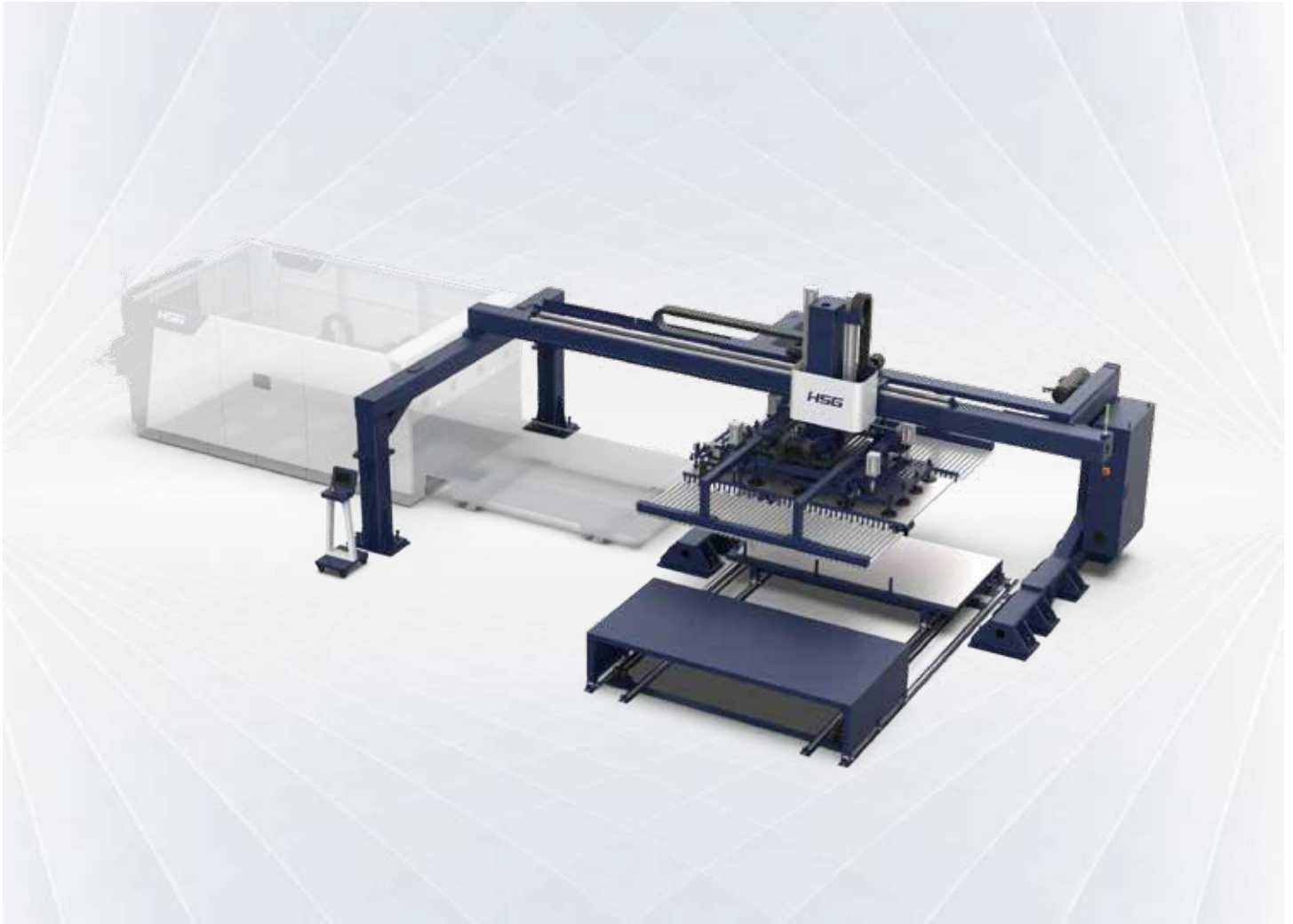

Technical Parameters

Model	ALG3015-200	ALG3015-400	ALG3015-800	ALG4020-400	ALG4020-800	ALG4020-1200
Matching Model Series				GX, GH		
Matching the size of the model	3015		4020			
Max Loading Weight	200kg	400kg	800kg	400kg	800kg	1200kg
Max Loading Sheet Size	3000mm*1500mm			4000mm*2000mm		

* Machine appearance, technical parameters, function description, data comparison shown in this page are from HSG in-house laboratory. All testing results and experimental data shall be subject to real machine.

ALM

Simple Structure | High-speed Loading and Unloading

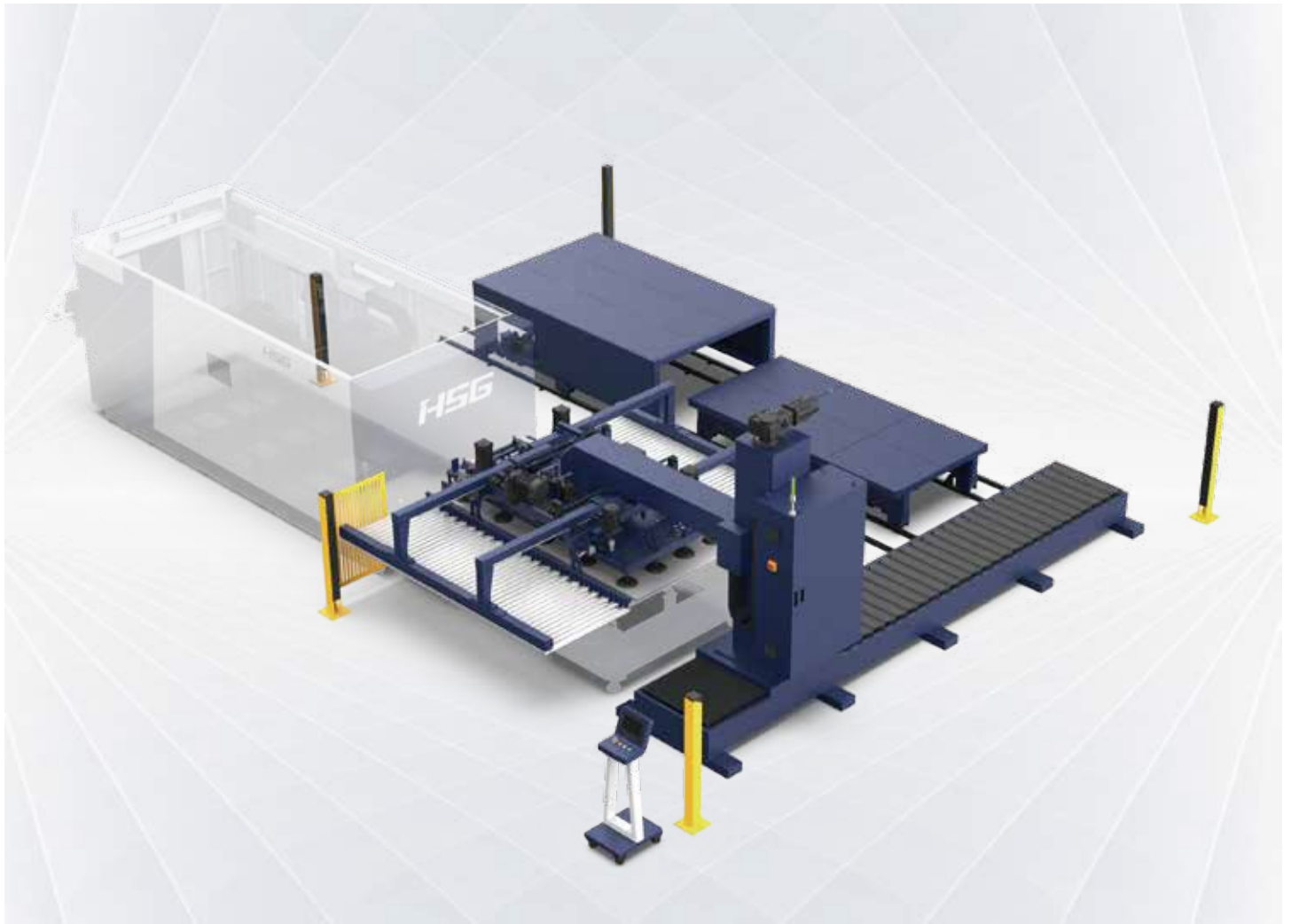

Technical Parameters

Model	ALM3015-200
Matching Model Series	GX
Matching the size of the model	3015
Max Loading Weight	200kg
Max Loading Sheet Size	3000mm*1500mm

* Machine appearance, technical parameters, function description, data comparison shown in this page are from HSG in-house laboratory. All testing results and experimental data shall be subject to real machine.

ALM-ECO

Easy Loading | Save Time and Effort | Highly Economical | Simple Installation



Technical Parameters

Model	ALM3015-500-ECO
Matching Model Series	GX, C
Matching the size of the model	3015
Max Loading Weight	500kg
Max Loading Sheet Size	3000mm*1500mm

* Machine appearance, technical parameters, function description, data comparison shown in this page are from HSG in-house laboratory. All testing results and experimental data shall be subject to real machine.



Intelligent Manufacturing Changes Future



As a global enterprise, HSG sticks to providing professional and convenient service support to customers at home and board



Professional Training

Multiple technical training service and free operation training for customers and dealers in time



Efficient Support

Humanistic service model, online services and 7*24 hotline to offer solutions and assistance



Optimized Transport

Multi-channel transport solutions and professional transport solution team will provide various transport cases for to satisfy the demand of customers and save transports fees



Sufficient Accessories

Highly efficient accessories delivery service, multiple network inventory jointly responds to accessories demand to shorten customer's waiting times and accelerate production



Careful Services

Domestic door-to-door service and free proofing, global 100+dealers provide efficient and convenient services



Intelligent Manufacturing Changes Future



Website



Facebook



Youtube

Headquarters Add.: No. 4, Anye Road, Shunjiang Community Industrial Park,
Beijiao Town, Shunde District, Foshan, Guangdong, China
Website: www.hsglaser.com
Email: info@hsglaser.com
Tel: +86 757-66833906