



Cutting | Bending | Welding | Automation



# HC

✦ Electro Hydraulic Servo Bending Machine ✦

## Company Culture

### MISSION

Intelligent manufacturing changes future

### VALUES

Customer-focused and employee-based

### VISION

Become a respectable enterprise in the global metal forming equipment field

## Company Profile



13

Global Branches



100+

Countries Covered



4

Manufacturing Bases



30+

Global Service Outlets

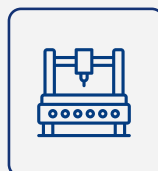

8,000+

Delivery Capability



96,000m<sup>2</sup>

Occupied Area

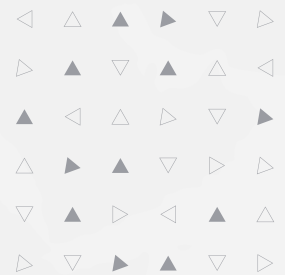

# HC

## Electro Hydraulic Servo Bending Machine



### Technical Parameters

| Product             | HC6015    | HC1703  | HC1704  | HC1103  | HC1104  | HC2203  | HC2504  | HC3204  | HC3206  | HC4004  | HC4006  |
|---------------------|-----------|---------|---------|---------|---------|---------|---------|---------|---------|---------|---------|
| Bending Force       | 600KN     | 1700KN  | 1700KN  | 1100KN  | 1100KN  | 2200KN  | 2500KN  | 3200KN  | 3200KN  | 4000KN  | 4000KN  |
| Main Motor Power    | 5.5KW     | 15.7KW  | 10.5KW  | 7.9KW   | 7.9KW   | 15.7KW  | 18.5KW  | 30KW    | 30KW    | 30KW    | 30KW    |
| Rapid Descent Speed | 200mm/s   | 180mm/s | 180mm/s | 200mm/s | 180mm/s | 180mm/s | 150mm/s | 120mm/s | 100mm/s | 90mm/s  | 90mm/s  |
| Return Speed        | 200mm/s   | 140mm/s | 140mm/s | 150mm/s | 140mm/s | 140mm/s | 120mm/s | 90mm/s  | 80mm/s  | 70mm/s  | 70mm/s  |
| Working Speed       | 10-15mm/s | 10mm/s  | 10mm/s  | 10mm/s  | 10mm/s  | 10mm/s  | 10mm/s  | 10mm/s  | 8mm/s   | 8mm/s   | 8mm/s   |
| Number of CNC Axes  | 4+1       | 4+1     | 4+1     | 4+1     | 4+1     | 4+1     | 4+1     | 4+1     | 4+1     | 4+1     | 4+1     |
| Equipment Weight    | 3500kg    | 11200kg | 12000kg | 9000kg  | 10200kg | 12000kg | 16000kg | 21500kg | 27000kg | 22000kg | 30000kg |
| Fuel Tank Capacity  | 200L      | 400L    | 400L    | 300L    | 400L    | 400L    | 400L    | 500L    | 700L    | 500L    | 700L    |

\* Machine appearance, technical parameters, function description, data comparison shown in this page are from HSG in-house laboratory. All testing results and experimental data shall be subject to real machine.

## Switzerland (CYBELEC) CybTouch 12PS Control System

- Automatically calculate bending angle, main pressure and deflection compensation.
- Correct the bending angle and back gauges.
- Make mass bending possible with high-efficient programming.
- Enable wireless interconnection via desktop or notebook computer for software upgrades and data backup anytime.

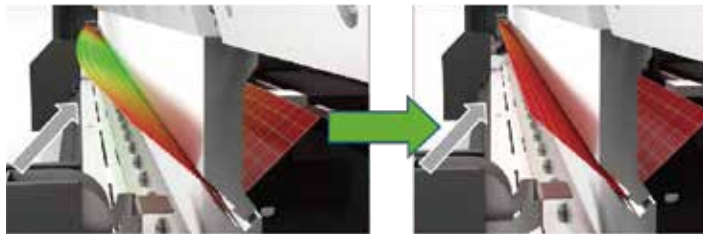

## Automatic Compensation System for Mechanical Deflection

- Compensate the bending station laterally and vertically.
- Calculate compensation based on length, thickness and angle of bending work-piece.
- Take accurate control of compensation precision as a result of high-precision potentiometer.

## Back Gauges Positioning System

- Servo motor drives it to move backward and forward (X-axis), up and down (Y-axis).
- Configure four positioning fingers to prevent materials from sagging and defectives caused by any error.



## Highly-rigid Heavy-duty Frame

- Welded by using high-quality carbon steel, creating high rigidity.
- Finite element analysis shows no deformation of frame.
- Once clamping and integral machining for totally guaranteed precision.



## Bending Follow-up Trolley (Optional)

- Independent control system, work with any on-site bending machine.
- Get started quickly because of easy operation and fool-proof settings.
- Single-axis linkage for semi-automatic operation to reduce bending difficulty and achieve quickly mass production.



## Safety Light Curtain (Optional)

- The machine will stop cutting immediately when any intruder is detected to protect both workers and the machine.

# Machine Foundation

\*The marked size has about 10mm error  
 \*Pictures of HC1103 are for reference only and subject to actual dimensions.

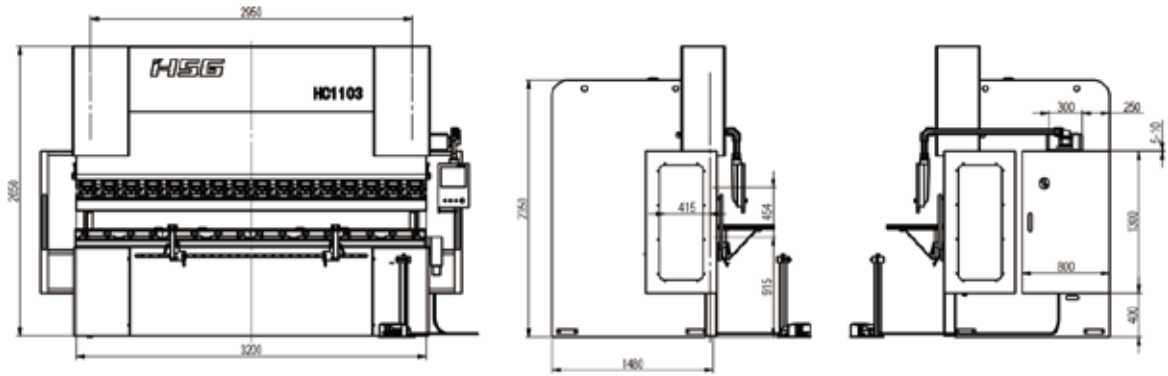

## Bending Samples



## Bending Capacity

| Project |      |     | mm  |     |     |     |     |     |     |     |     |     |     |     |     |     |     |     |     |     |     |    |    |  |
|---------|------|-----|-----|-----|-----|-----|-----|-----|-----|-----|-----|-----|-----|-----|-----|-----|-----|-----|-----|-----|-----|----|----|--|
| v       | b    | ir  | 0.5 | 0.6 | 0.8 | 1.0 | 1.2 | 1.4 | 1.6 | 2.0 | 2.3 | 2.6 | 3.0 | 3.2 | 3.5 | 4.0 | 4.5 | 5.0 | 6.0 | 7.0 | 9.0 | 10 | 12 |  |
| 4       | 2.8  | 0.7 | 40  | 60  |     |     |     |     |     |     |     |     |     |     |     |     |     |     |     |     |     |    |    |  |
| 6       | 4    | 1   |     | 40  | 70  | 110 |     |     |     |     |     |     |     |     |     |     |     |     |     |     |     |    |    |  |
| 7       | 5    | 1.1 |     | 40  | 70  | 100 | 140 |     |     |     |     |     |     |     |     |     |     |     |     |     |     |    |    |  |
| 8       | 5.5  | 1.3 |     | 30  | 50  | 80  | 120 | 150 |     |     |     |     |     |     |     |     |     |     |     |     |     |    |    |  |
| 10      | 7    | 1.6 |     |     | 40  | 70  | 100 | 130 | 170 |     |     |     |     |     |     |     |     |     |     |     |     |    |    |  |
| 12      | 8.5  | 2   |     |     |     | 60  | 80  | 110 | 150 | 220 |     |     |     |     |     |     |     |     |     |     |     |    |    |  |
| 14      | 10   | 2.3 |     |     |     |     | 70  | 100 | 130 | 190 | 250 |     |     |     |     |     |     |     |     |     |     |    |    |  |
| 16      | 11   | 2.6 |     |     |     |     | 60  | 90  | 110 | 170 | 230 | 280 |     |     |     |     |     |     |     |     |     |    |    |  |
| 18      | 13   | 3   |     |     |     |     |     | 80  | 100 | 150 | 190 | 250 | 340 |     |     |     |     |     |     |     |     |    |    |  |
| 20      | 14   | 3.3 |     |     |     |     |     |     | 90  | 130 | 170 | 220 | 300 | 340 |     |     |     |     |     |     |     |    |    |  |
| 25      | 17.5 | 4   |     |     |     |     |     |     |     | 110 | 150 | 180 | 240 | 270 | 330 | 430 |     |     |     |     |     |    |    |  |
| 32      | 22   | 5   |     |     |     |     |     |     |     |     | 120 | 140 | 190 | 220 | 260 | 340 | 430 |     |     |     |     |    |    |  |
| 40      | 28   | 6.5 |     |     |     |     |     |     |     |     |     | 150 | 170 | 200 | 270 | 340 | 420 |     |     |     |     |    |    |  |
| 50      | 35   | 8   |     |     |     |     |     |     |     |     |     |     | 140 | 160 | 210 | 270 | 330 | 480 |     |     |     |    |    |  |
| 63      | 45   | 10  |     |     |     |     |     |     |     |     |     |     |     | 130 | 170 | 210 | 260 | 380 | 520 |     |     |    |    |  |
| 80      | 55   | 13  |     |     |     |     |     |     |     |     |     |     |     |     |     | 210 | 300 | 410 | 670 | 850 |     |    |    |  |
| 100     | 71   | 16  |     |     |     |     |     |     |     |     |     |     |     |     |     |     | 240 | 330 | 430 | 670 | 960 |    |    |  |
| 125     | 89   | 20  |     |     |     |     |     |     |     |     |     |     |     |     |     |     |     | 260 | 430 | 530 | 780 |    |    |  |
| 160     | 113  | 24  |     |     |     |     |     |     |     |     |     |     |     |     |     |     |     |     |     | 420 | 600 |    |    |  |
| 125     | 140  | 33  |     |     |     |     |     |     |     |     |     |     |     |     |     |     |     |     |     |     | 500 |    |    |  |

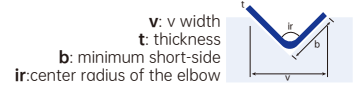

The actual machines shall prevail and above data & pictures are only for reference.



## Intelligent Manufacturing Changes Future



**As a global enterprise, HSG sticks to providing professional and convenient service support to customers at home and board**



### Professional Training

Multiple technical training service and free operation training for customers and dealers in time



### Efficient Support

Humanistic service model, online services and 7\*24 hotline to offer solutions and assistance



### Optimized Transport

Multi-channel transport solutions and professional transport solution team will provide various transport cases for to satisfy the demand of customers and save transports fees



### Sufficient Accessories

Highly efficient accessories delivery service, multiple network inventory jointly responds to accessories demand to shorten customer's waiting times and accelerate production



### Careful Services

Domestic door-to-door service and free proofing, global 100+dealers provide efficient and convenient services



Intelligent Manufacturing Changes Future



Website



Facebook



Youtube

Headquarters Add.: No. 4, Anye Road, Shunjiang Community Industrial Park,  
Beijiao Town, Shunde District, Foshan, Guangdong, China  
Website: [www.hsglaser.com](http://www.hsglaser.com)  
Email: [info@hsglaser.com](mailto:info@hsglaser.com)  
Tel: +86 757-66833906